

ASCO
NUMATICS™

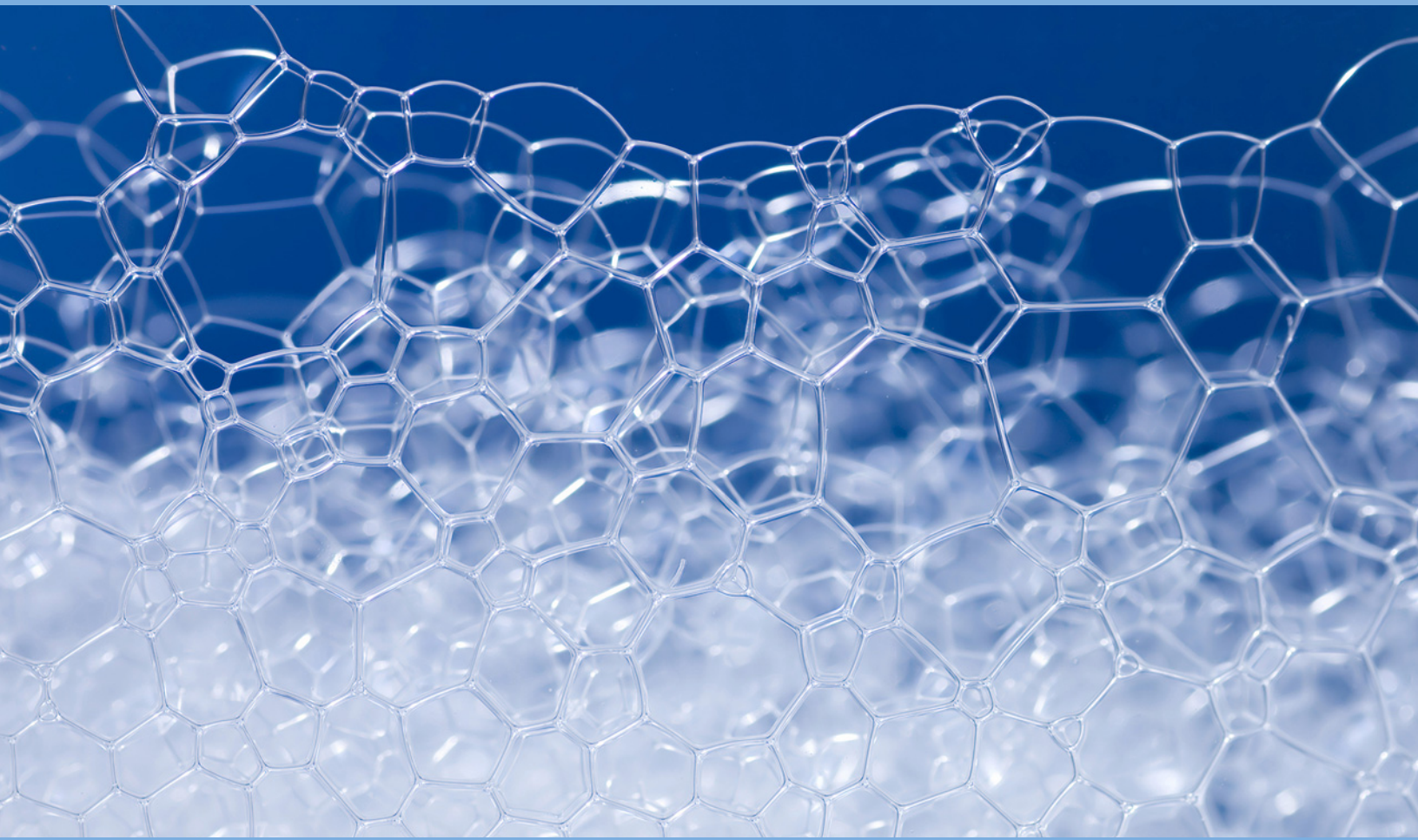

Fluid Automation Solutions

for Commercial and Industrial Laundries

www.asconumatics.com

EMERSON™
Industrial Automation



Choose ASCO Numatics as your single source of fluid automation solutions for laundry equipment designs. Performance, dependability, and low cost of ownership characterize our wide range of superior products.

Presenting ASCO Numatics solutions

The clean winner for laundry

ASCO Numatics valves and other products are fast becoming the choice of leading original equipment manufacturers (OEMs) for cold and hot water, steam, air, and fuel gas handling in commercial and industrial laundry equipment.

Our winning solutions help machine designers improve their competitive advantage. Now OEMs can offer their customers optimized outputs, increased throughputs, and reduced downtimes. Features such as high water flow rates help washers fill faster. Greater gas flows provide higher heat output for faster drying and cycling. Commercial and industrial laundries can improve productivity, save energy, and provide higher quality service to their customers.

Apply everywhere

Our products can be utilized in practically any part of the laundry operation. Laundry equipment leaders specify ASCO Numatics for applications at numerous stages of the process, including:

- Washing
- Pressing
- Drying
- Separating
- Ironing
- Folding

There are literally hundreds of ways that your designs can take advantage of ASCO Numatics performance and reliability. Don't hesitate to ask for what you need.

ASCO Numatics advantages

Reliability and long life. ASCO Numatics products emphasize durable build quality and robust components for greatly extended life cycles. So your customers can cut maintenance costs and maximize their uptimes.

High flow and high pressure. Specify ASCO Numatics for your most challenging applications. Where appropriate, our products are rated for the higher water or gas flows and the higher steam flows and pressures your customers demand. They get faster fills and hotter drying for reduced cycle times and greater throughput.

Consistent response. Our products are precisely designed and machined for rapid, repeatable operation. For example, the fast, dependable response times of our solenoid valves are critical for accurate, crisp, consistent folding of ironed items.

Low cost of ownership. ASCO Numatics products install more easily, run longer, and require less maintenance. These advantages translate into less trouble for you — and considerable savings for your customers.

Compact design. Our offerings feature smaller footprints and low profiles. Their minimal size allows you plenty of room for other components in tight equipment spaces.

Minimized inventory. Whenever possible, we design our products for multipurpose use. For instance, our steam valves perform superbly on both water and steam. This lets you standardize on specifying fewer but better products, while allowing your customers to stock fewer spare parts.

Swift serviceability. Should our products require maintenance, they're designed to make it fast and easy. Also, with the largest presence of any fluid automation supplier, ASCO Numatics can deliver consistent local service, parts replacement, and technical support anywhere in the USA.

Ensured availability. ASCO Numatics is a comprehensive solutions provider with the broadest product line in our business. You and your customers get convenient local stocking, popular ASCO Today guaranteed same-day shipment on many items, and the industry's most robust distribution network. So you get what you need, just when you need it. One call does it all.



The assurance of leadership

ASCO Numatics, a division of Emerson, offers comprehensive flow control and pneumatics solutions for a wide range of industry-focused applications. The ASCO Numatics line comprises more than 50,000 valves, an extensive selection of air preparation equipment, and a comprehensive line of motion control products. The company is the world's leading manufacturer of solenoid valves.

Emerson (NYSE: EMR), based in St. Louis, Missouri, U.S.A., is a global leader in bringing technology and engineering together to create innovative solutions for customers through its network power, process management, industrial automation, climate technologies, and appliance and tools businesses. Sales in fiscal 2008 were \$24.8 billion.

To build in performance and reliability while lowering the cost of ownership for commercial and industrial laundry equipment, get in touch with ASCO Numatics today!

Key solutions



ASCO Angle-Body Piston Valves

These rugged valves are designed for water and high-pressure steam applications with pipe sizes 2 1/2 inches or smaller and up to 150 psi. They accommodate rapid cycling, eliminate water hammer, and create tight shutoff in both directions. Apply them in batch washers, heavy-duty washers, dry cleaning, as well as on the recycling skid.



ASCO Steam/Hot Water Valves

Get up to 60% higher flow, while increasing throughput when you specify these popular high-flow, long-life models. They reduce inventories by accommodating both steam and hot water service, and are designed for quick, easy maintenance. Apply them with confidence especially in heavy-duty washers, and ironing equipment.



ASCO Solenoid Pilot Valves

These robust valves are designed to meet the high cycling demands of today's commercial and industrial laundries. Couple them with spring-return and double-acting cylinders for use in applications such as heavy-duty washing, pressing, ironing, and folding.

Batch Washing

● Angle-Body Piston Valves

Soiled Material

Pressing

- Pneumatic Actuators
- Solenoid Pilot Valves
- FRLs



Numatics Air Bellows

Provide a quiet, consistent suspension system for vibrating, noisy machinery. These bellows are ideal for shock-absorbing use in demanding applications such as heavy-duty washer equipment.

Soiled Material

Heavy-Duty Washing

- Angle-Body Piston Valves
- Steam/Hot Water Valves
- General-Purpose Solenoid Valves
- Air Bellows

Drying

- Combustion Valves



ASCO Combustion Valves

Choose from the industry's broadest line of solenoid and electrohydraulic gas shutoff valves. Leading OEMs specify these for the control of fuel gas in main and pilot gas train applications on all brands of drying equipment. Some models provide extremely high flows, allowing economical downsizing of the fuel train.



ASCO General-Purpose Solenoid Valves

ASCO Numatics offers the widest range of solenoid valves on the market. Our proven, dependable models are ideal for air or liquid flow. Our high flows provide your customers with more cycles and greater throughput. Applications range from cold and hot water handling of inlet flows in heavy-duty washers to consistent-response air control in folding equipment.



Numatics Fittings & Accessories

Our wide selection of push-to-connect fittings provides instant connection and seal, extreme versatility in use, while at the same time maintaining optimum flow. Other accessories include NPTF/inch tube fittings, metric fittings, metering valves, check valves, inline and right angle flow controls, and assorted brass fittings. Apply them everywhere in your laundry operation equipment.

Drying

● Combustion Valves

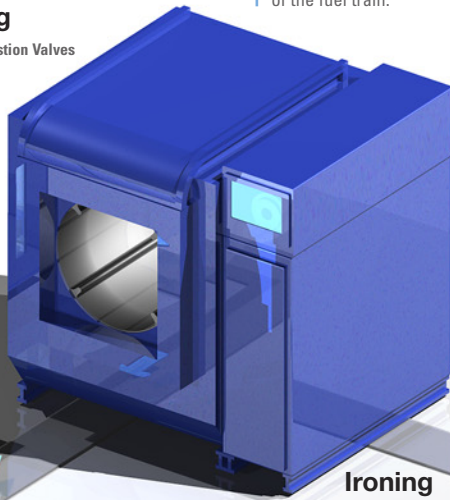

Ironing

- Steam/Hot Water Valves
- Pneumatic Actuators
- Solenoid Pilot Valves
- FRLs

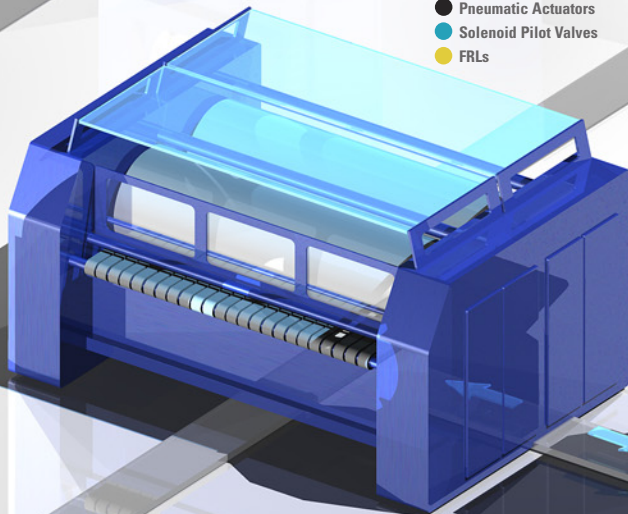

Folding

- Pneumatic Actuators
- Solenoid Pilot Valves
- General-Purpose Solenoid Valves
- FRLs

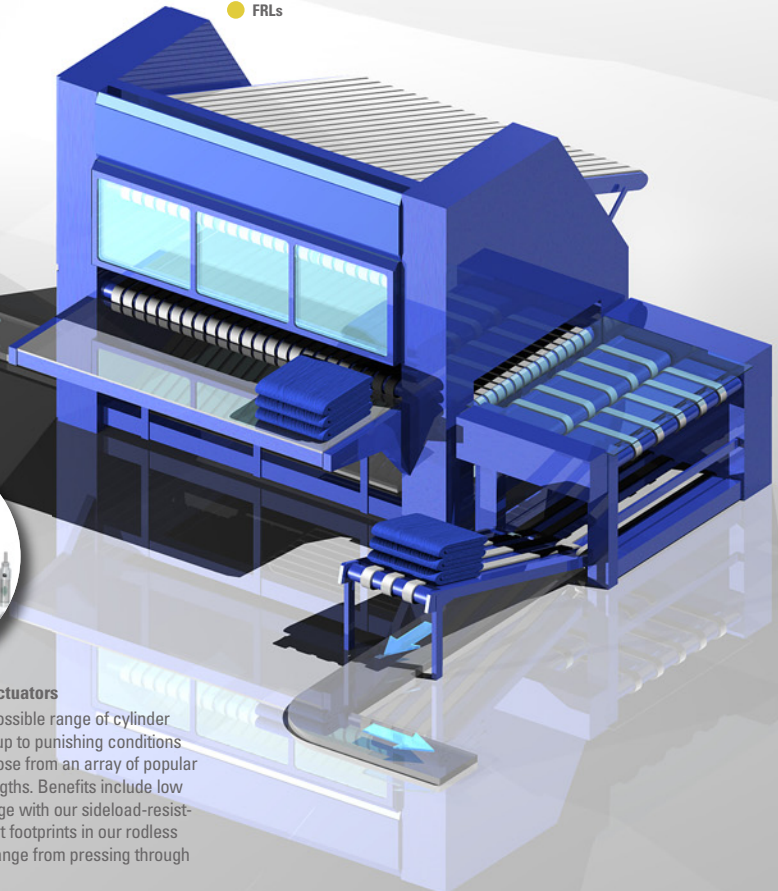

Numatics FRLs

Our filters, regulators, and lubricators provide superior treatment of air quality and pressure for your pneumatic laundry equipment, from pressing through ironing and folding. These high-performance products are available in multiple configurations. Standardize on Numatics FRLs to help minimize inventories for yourself and your customers.



Numatics Pneumatic Actuators

Select from the widest possible range of cylinder products made to stand up to punishing conditions in the laundry room. Choose from an array of popular bore sizes and stroke lengths. Benefits include low risk of rod thread breakage with our sideload-resistant designs, and compact footprints in our rodless cylinders. Applications range from pressing through ironing and folding.

Global Contacts

www.asconumatics.com

ASCO

Location	Phone	E-mail
World headquarters (U.S.A.)	(1) 800-972-ASCO (2726)	info-valve@asco.com
Canada	(1) 519-758-2700	
Australia	(61) 2-9-451-7077	
Brazil	(55) 11-4208-1660	
Mexico	(52-1) 728-28-51-238	
France	(33) 1-47-14-32-00	
Germany	(49) 7237-9960	
United Kingdom	(44) 1695-713600	
China	(86-10) 8563-1122	
Singapore	(65) 6556-1100	
Japan	(81) 798-65-6361	



NUMATICS

Location	Phone	E-mail
World headquarters (U.S.A.)	(1) 248-596-3200	marketing@numatics.com
U.S.A.		
Numatics air preparation	(1) 810-667-3900	
Numatics valves	(1) 248-596-3200	
Numatics miniature valves	(1) 248-596-3200	
Numatics motion control	(1) 615-771-1200	
Numatics rodless cylinders	(1) 519-452-1777	
Canada		
Numatics, Ltd. Ontario	(1) 519-452-1777	
Numatics, Ltd. Quebec	(1) 514-332-6444	
Numatics, Ltd. British Columbia	(1) 604-538-0400	
Mexico		
Numatics de Mexico S.A. de C.V.	(52) 222-284-6176	

ASCO
numatics™